

PART NUMBER	ROHS COMPLIANT
50025-000	NO
50025-777	YES, AS PER NOTE 4

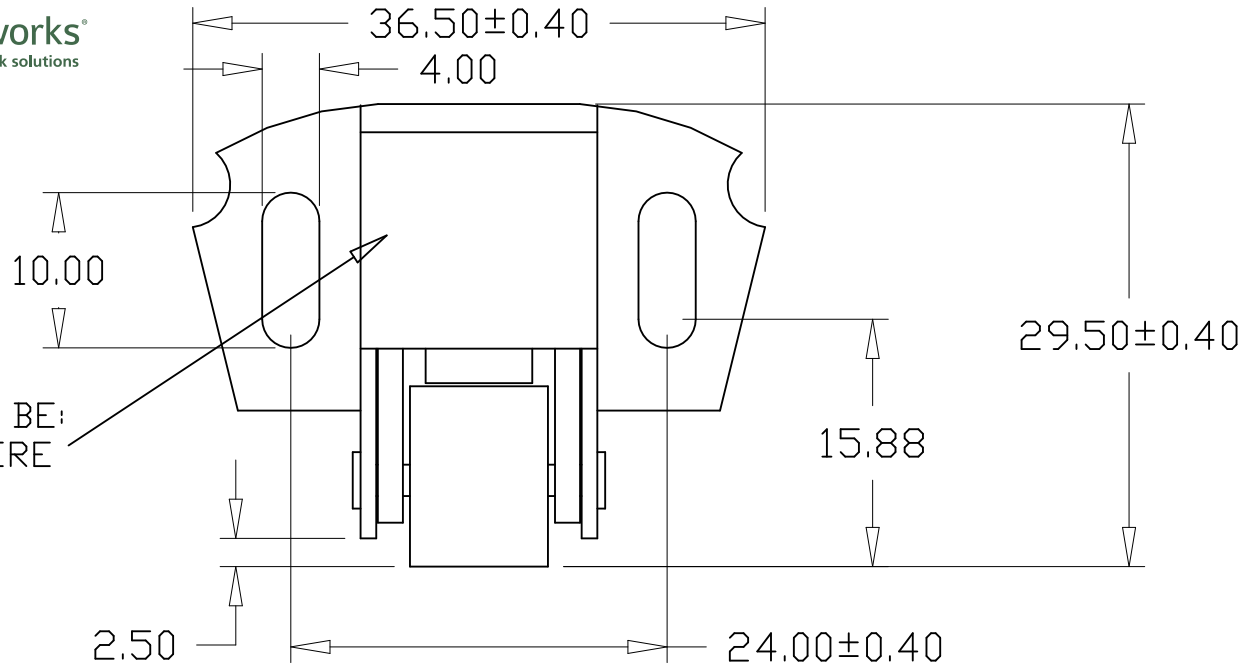

COIL SPRING TO BE:
 0.96 Ø ROUND WIRE
 8 COILS
 5.80 Ø OVERALL

REVISIONS			
REV	DESCRIPTION	DATE	APPROVED
A	Revision #98-128	1/1/99	KGH
B	Revision #00-296	1/17/00	KGH
C	Revision #06-1375	8/15/06	K.Houlihan

NOTE: Proprietary Rights are included in the information disclosed herein. This information is submitted in confidence and neither this document nor the information disclosed herein shall be reproduced or transferred to other documents or used to disclose to others for manufacturing or any other purposes except as specifically authorized in writing by Wind Corporation

NOTES:

- 1) ROLLER COMPRESSION LENGTH IS 5.40 mm.
- 2) NO SHARP EDGES OR BURRS.
- 3) ALL DIMENSIONS ARE IN MM.
- 4) ALL PIECES MUST BE "ROHS" COMPLIANT, FOR P/N 50025-777, AS PER TABLE.
- 5) EXPORT CARTON MARKINGS AS PER DOCUMENT NUMBER "PCK101."



		Tolerance unless otherwise specified:		DRAWING TITLE	
		Decimal: ± .005" ± .13mm Fractions: ± 1/64" Angles: ± 1°		Roller Catch	
MATERIAL: Steel, Plastic		SIZE: A	DWG NO. 50025 (See Table)	REV: C	REV DATE: 08/15/06
FINISH: Zinc, Roller White		SCALE: 2:1	DRAWN BY: MAG	DATE: 01/06/99	SHEET 1 OF 1