

Hinges

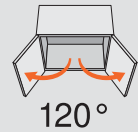

CLIP top 120°



Features

- Three-dimensional adjustment
- Available with INSERTA attachment
- For door thicknesses up to 22 (7/8")
- All metal hinge, nickel-plated
- Add-on BLUMOTION soft close available

Minimum reveal table					
3	1.2	1.7	2.0	2.4	3.3
4	1.2	1.7	2.0	2.3	3.1
5	1.1	1.6	1.9	2.2	3.0
6	1.1	1.6	1.9	2.2	2.9
B = boring distance	16	18	19	20	22
	T = door thickness				

Thickness greater than 22 trial recommended

Overlay

Frame

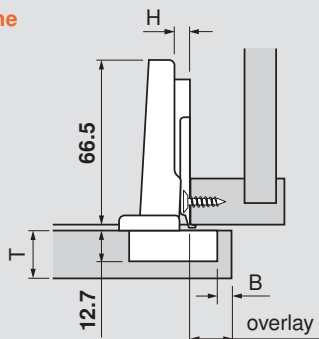

Frameless

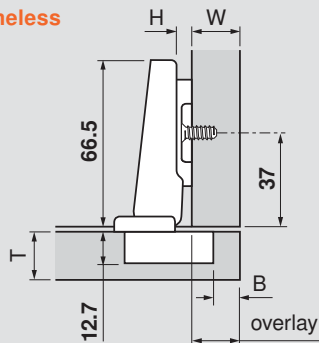

Partial/twin overlay

Frame

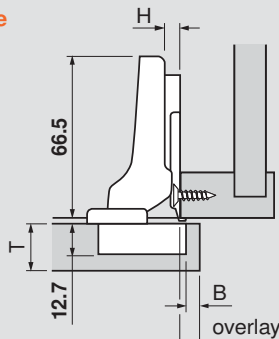

Frameless

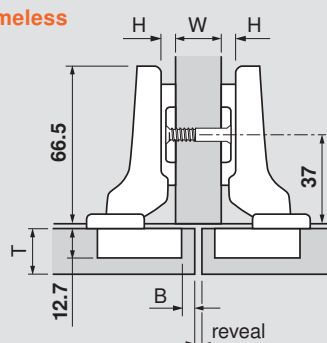

Inset

Frame

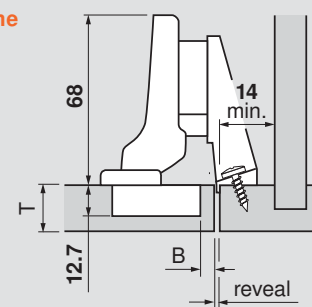

NOTE: Application requires a half-cranked hinge and mounting plate 175H5030.21

Frameless

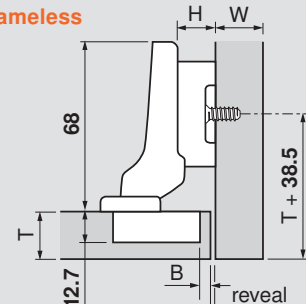

H	Overlay					P	S
0	14	15	16	17	11.5	20.5	
3	11	12	13	14	14.5	23.5	
4.5	9.5	10.5	11.5	12.5	16	25	
6	8	9	10	11	17.5	26.5	
9	5	6	7	8	20.5	29.5	
	3	4	5	6	Fixed distance = 11		
	B = boring distance						

NOTE: 4.5 plate is only for use in face frame cabinets, 9 plate is only for frameless cabinets

H	Overlay				P	S	
0	4.5	5.5	6.5	7.5	21.5	30	
	3	4	5	6	Fixed distance = 1.5		
	B = boring distance						
H	Reveal				W	P	S
0	7	5	3	1	16	21.5	30
	10	8	6	4	19		
	13	11	9	7	22		
	3	4	5	6	B = boring distance		
	B = boring distance						

H	Reveal				P	S
9	4.5	3.5	2.5	1.5	30.5	39
	3	4	5	6	Fixed distance = -7.5	
	B = boring distance					

Abbreviations

H	=	Plate height
P	=	Door protrusion
S	=	Side arm protrusion
W	=	Side panel width

Straight-arm	Self close
Screw-on	71T5550
Press-in	71T5580
INSERTA	71T5590B
EXPANDO	71T558E

Half-cranked	Self close
Screw-on	71T5650
Press-in	71T5680
INSERTA	71T5690B

Half-cranked	Self close
Screw-on	71T5650
Press-in	71T5680
INSERTA	71T5690B

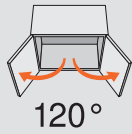

CLIP top 120°+

Hinges



Features

- For larger overlays (21 mm maximum)
- Three-dimensional adjustment
- Available with INSERTA attachment
- For door thicknesses up to 22 (7/8")
- All metal hinge, nickel-plated
- Add-on BLUMOTION soft close available



Minimum reveal table					
3	1.2	1.7	2.0	2.4	3.3
4	1.2	1.7	2.0	2.3	3.1
4.5	1.1	1.6	1.9	2.2	3.0
5	1.1	1.6	1.9	2.2	3.0
6	1.1	1.6	1.9	2.2	2.9
B = boring distance	16	18	19	20	22
T = door thickness					

Thickness greater than 22 trial recommended

CLIP top

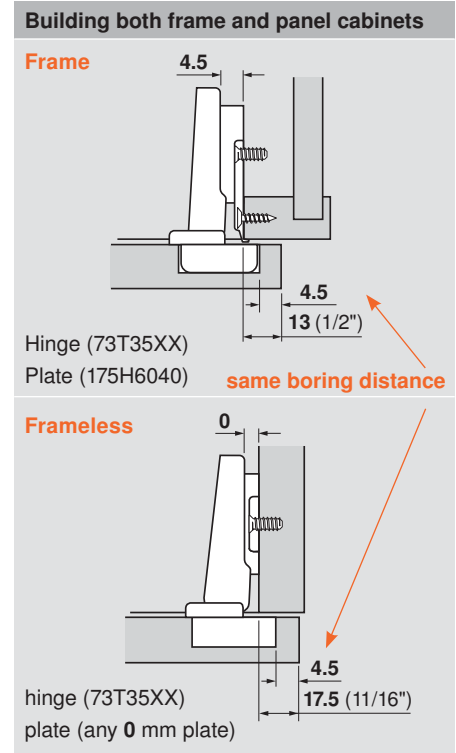
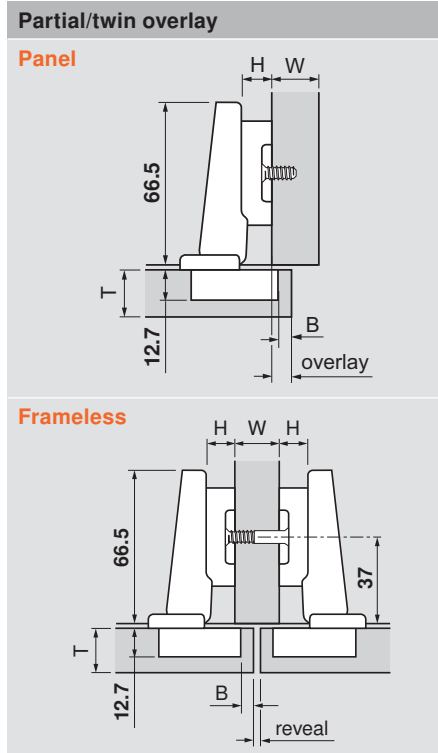
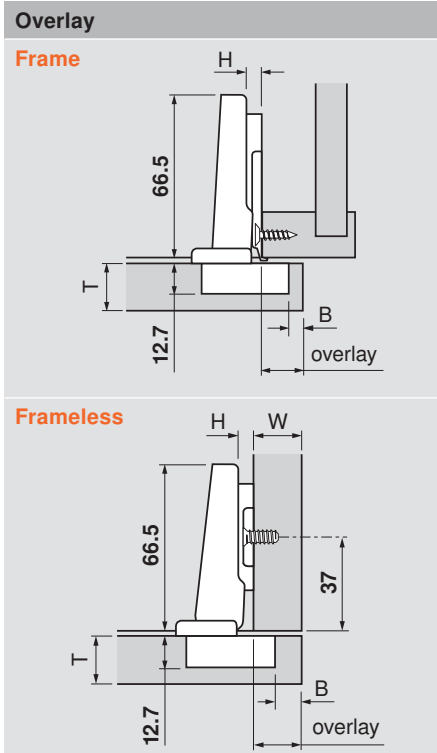

H	Overlay						P	S
0	16	17	17.5	18	19	12	21.5	
3	13	14	14.5	15	16	15	24.5	
4.5	11.5	12.5	13	13.5	14.5	16.5	26	
6	10	11	11.5	12	13	18	27.5	
9	7	8	8.5	9	10	21	30.5	
	3	4	4.5	5	6	Fixed distance = 13		
	B = boring distance							

NOTE: 4.5 plate is only for use in face frame cabinets, 9 plate is only for frameless cabinets

H	Overlay						P	S
9	7	8	8.5	9	10	18.5	28	
	3	4	4.5	5	6	Fixed distance = 13		
	B = boring distance							

H	Reveal					W	P	S
	2	-	-	-	-	16		
9	5	3	2	-	-	19	18.5	28
	8	6	5	4	-	22		
	3	4	4.5	5	6	B = boring distance		

The most common overlays for frame and frameless cabinets can be achieved by using the same machine setting for hinge cup boring.

Bore all doors at 4.5 mm to achieve:

- 13 (1/2") overlay on frame cabinets
- 17.5 (11/16") overlay on frameless cabinets

Advantages:

- One machine setting for boring all doors
- Same hinge used for both applications

Straight-arm	Self close
Screw-on	73T5550
Press-in	73T5580
INSERTA	73T5590B
EXPANDO	73T558E

Straight-arm	Self close
Screw-on	73T5550
Press-in	73T5580
INSERTA	73T5590B
EXPANDO	73T558E

Abbreviations	
H	= Plate height
P	= Door protrusion
S	= Side arm protrusion
W	= Side panel width